

# STC

## 100

REF. 4465





# Contents

## **4 General safety instructions**

- 4 Types of notices
- 5 Basic safety instructions

## **6 Introduction**

- 6 General description
- 7 General use of the headend

## **8 Basic installation and configuration**

- 8 Assembly, connection of signals and power supply
- 9 Description of the user interface
- 10 IKUNET bus configuration
- 14 Configuration of general parameters
- 15 Module configuration
- 20 Service Management

## **23 Advanced functions**

- 23 Save/Restore Function
- 23 Internet Access
- 24 Network functions
- 25 Advanced global transport processing
- 26 Reports

## **30 CE Certificate**

- 30 STC-201

# General safety instructions

- Read all of this user manual carefully before plugging in the unit.
- Always have these instructions to hand during installation.
- Follow all of the instructions and safety notices regarding unit handling.

## Types of notices

The meaning of the safety notices used in this manual are described below.



### DANGER OF DEATH OR INJURY

This safety notice indicates a possible danger for the life and health of people. Not following these instructions may lead to serious consequences to health and may even cause fatal injuries.



### RISK OF DAMAGE TO THE UNIT

This safety notice indicates a possible dangerous situation. Not following these instructions may lead to the unit being damaged.



### NOTE

This type of notice is a note containing applicable advice and useful information for optimum use of the unit.



### HANDLING THE INSIDE OF THE UNIT IS FORBIDDEN

This notice forbids any work that may affect the working order of the unit or its warranty.



### DO NOT DISPOSE OF AS URBAN WASTE

This type of notice indicates that the unit must not be disposed of as unselected urban waste.



## Basic safety instructions



### DANGER OF DEATH OR INJURY

- Do not install the unit during an electrical storm. This could lead to electrostatic discharge from lightning.
- Do not open the unit. There is a risk of electrostatic discharge.



### RISK OF DAMAGE TO THE UNIT

- The unit must be appropriately ventilated. Install the unit in a dust-free location. Do not place the unit in a location where the ventilation slots are covered or blocked. Install the unit in a location with at least 20 cm around it free of other objects.
- Do not expose the unit to rain or moisture. Install the equipment in a dry location with no infiltration or condensation of water. Should a liquid enter the unit, disconnect it immediately from the mains.
- Keep the unit away from flammable objects, candles and anything that may cause a fire.
- Connect the unit to an easily accessible power socket. In the event of an emergency, it will then be possible to quickly unplug the unit.
- Do not expose the unit to sources of heat (sun, heating, etc.).

## Introduction

- To ensure the correct use and installation of the headend, it is necessary to read the user and troubleshooting procedure manuals corresponding to the complete solution and to each of the individual modules.
- IKUSI reserves the right to modify the contents of this manual without prior warning.

## General description

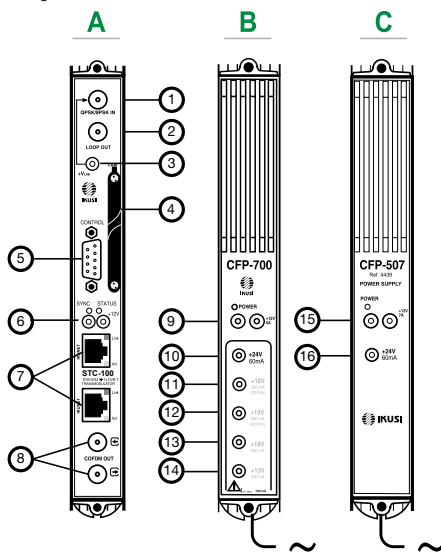

### KEY

- Ⓐ STC-100 module
- Ⓑ CFP-700 module
- Ⓒ CFP-507 module
- ① Input 1 DVB-S/S2 channel
- ② Loop output
- ③ LNB remote power supply
- ④ Slot for CAM
- ⑤ DB-9 port
- ⑥ DC power supply

- ⑦ RJ-45 ports for IKUNET bus
- ⑧ Coupling loop DVB-T output
- ⑨ Output +12 V (5 A)
- ⑩ Output +24 V (60 mA)
- ⑪ Output +18 V/22 kHz (300 mA)
- ⑫ Output +13 V/22 kHz (300 mA)
- ⑬ Output +18 V/0 kHz (300 mA)
- ⑭ Output +13 V/0 kHz (300 mA)
- ⑮ Output +12 V (7 A)
- ⑯ Output +24 V (60 mA)

The headend described in this manual is made up of the following modules:

- STC-100 (Ref. 4465): DVB-S/S2 to DVB-T transmodulator (QPSK/8PSK to COFDM).
- CFP-507 (Ref. 4439): power supply +12 V/+24 V.

- CFP-700 (Ref. 4401): power supply +12 V/+24 V for selection of polarisation.
- BAS-900 (Ref. 4411): base-support with capacity for 9 modules (dimensions: 563x257x24 mm).
- MS-0504 (Ref. 1023): stand-alone multiswitch (4 SAT inputs and 4 outputs).



**NOTE**

Please read the detailed information in the manuals for the modules included in their respective packaging.

## General use of the headend

This headend is designed for the emission of DVB-T (COFDM) signals from the input of free or encrypted DVB-S/S2 signals (QPSK/8PSK to COFDM).



**NOTE**

The DVB-T (COFDM) output signal requires a trunk amplifier for the correct distribution in installations for a large number of sockets.

## Basic installation and configuration



### NOTE

A PC with an Ethernet network card and a CAT-5E Ethernet crossover cable are required for communication with the headend.



### NOTE

To display the graphics provided in the headend configuration program correctly, we recommend installing the Mozilla Firefox web browser ([www.mozilla.com](http://www.mozilla.com)) in the control PC.

## Assembly, connection of signals and power supply

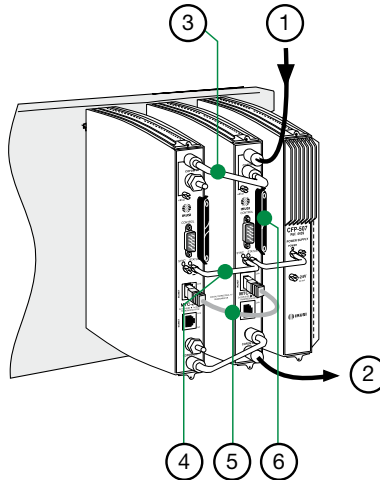

### KEY

- |                              |   |
|------------------------------|---|
| ① DVB-S/S2 signal input      | ④ Power supply bridges                            |
| ② DVB-T signal output        | ⑤ IKUNET  |
| ③ Bridging line in loop mode | ⑥ CAM + SmartCard + protection with safety screws |

- 1) Attach the modules to the base one by one following the instructions given in the manuals for each module.



### NOTE

IKUSI recommends the modules are assembled in the order shown in the above figure:

- Right: CFP-700/CFP-507 power supplies.
- Left: STC-100 transmodulators



- Last STC-100 on the right: Master STC-100 with the DVB-T output signal.
- 2) Connect the input and output signal connections in accordance with the instructions for the module manuals and the diagram shown in the previous figure.
  - 3) Distribute the headend power supply as symmetrically as possible (see example in above figure).

## Description of the user interface

The interface permits the user to communicate easily and comfortably with the headend. The layout of the menus and submenus of the interface is shown in the following diagram:

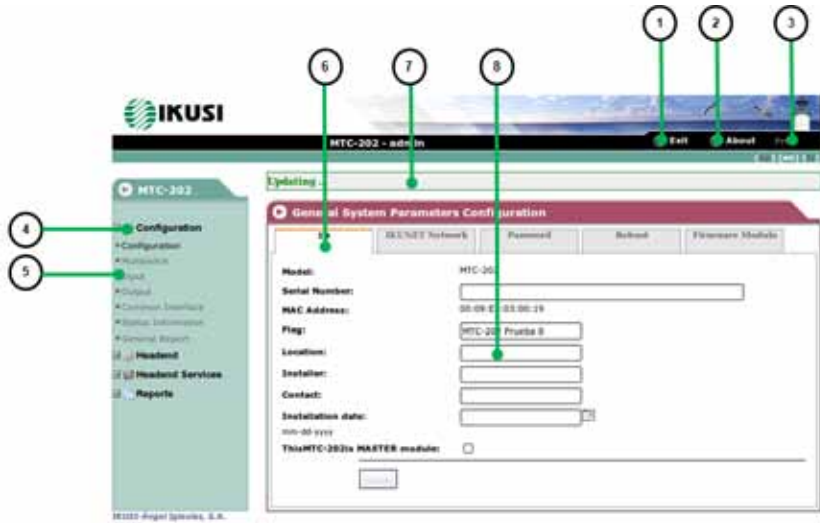

### KEY

- |                      |                  |
|----------------------|------------------|
| ① Exit button        | ⑤ Submenus       |
| ② Information button | ⑥ Tabs           |
| ③ Print button       | ⑦ Status message |
| ④ Main menu          | ⑧ Work area      |

The upper part of the interface displays messages about the communication status with the headend. Each message is colour-coded:

- Green: notifies that the instruction has been carried out.
- Red: indicates that the instruction could not be performed and gives the reason.

## IKUNET bus configuration

The IKUNET bus is an Ethernet communication bus between the headend modules. The IKUNET bus is installed using Ethernet pigtails supplied with the modules. If  $n$  is the number of station modules,  $n-1$  Ethernet pigtails are required.

### Definition of the master module



#### NOTE

- Remember the PC configuration prior to the connection with the IKUNET bus.
- The definition of the master module must be made with an STC-100 module.



#### NOTE

In mixed STC and MTC configurations, an STC module may never be an MTC module master. In these cases, the master module must be an MTC module and the STC modules are reserved for configuration as slave modules.

- 1) Start the configuration of the IKUNET bus for the headend with the modules disconnected from each other.
- 2) Connect the selected module (A) to the PC ( B ) via its Ethernet connection and using an RJ-45 cable ( C ).
- 3) In the PC (Windows XP) go to START > CONTROL PANEL > NETWORK CONNECTIONS > LOCAL AREA CONNECTION > PROPERTIES > INTERNET PROTOCOL (TCP/IP) > PROPERTIES.
- 4) Select the USE THE FOLLOWING IP ADDRESS checkbox. Enter the following IP configuration parameters:
  - IP ADDRESS: 10.254.254.2
  - SUBNET MASK: 255.255.255.0
  - DEFAULT GATEWAY: 10.254.254.1

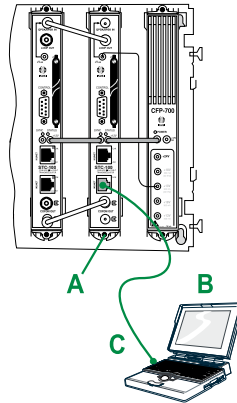

- 5) Click on the ACCEPT button.
- 6) Enter the IP address <http://10.254.254.254> in the web browser. This takes you to the home page of the connected module.

- 7) In the home page of the selected module, “Admin” appears by default in the USER field. Enter the word “admin” in the PASSWORD field and click on ACCEPT.
- 8) The main management window for the STC-100 module as slave module is displayed.



**NOTE**

The module with which you have connected the PC disconnects automatically after 15 minutes without interaction.

- 9) In the main menu, click on Master MODULE > CONFIGURATION. The GENERAL SYSTEM PARAMETERS CONFIGURATION window is displayed, with the INSTALLATION DATA tab.
- 10) Enter the name of the module in the MODULE NAME field.



**NOTE**

IKUSI recommends you give a description to the module according to its position in the headend in order to identify the modules logically and physically. For example, for a configuration identical to that proposed in the assembly section, include the following identifications (on the base, from right to left: STC-1 MASTER, STC-2).



- 11) To activate the module as master of the head-end, click on the THIS STC-100 IS THE MASTER MODULE checkbox. The module will be configured as master once the window has been saved.



**CAUTION**

If the background of the field is red, this means that the data has been modified but has not yet been saved. Before changing to another window or tab, any modified data must be saved (click on SAVE). Otherwise, the modified data will be lost and the previous information state will be maintained in the headend.



**NOTE**

If the IKUNET bus is connected to another Ethernet bus, we recommend you limit the IP range to the number of slave modules in the IKUNET bus, so that these can be identified more easily.

- 12) Click on EXIT in the main screen (top right corner).

## Name of slave modules

Continue without connecting the IKUNET bus.

Follow the steps below for each of the remaining modules of the headend (slave modules).

- 1) Connect the selected module (A) to the PC (B) via its Ethernet connection and using an RJ-45 cable (C).
- 2) Enter the IP address `http://10.254.254.254` in the web browser. This takes you to the home page of the connected module.
- 3) In the home page of the selected module, "Admin" appears by default in the USER field. Enter the word "admin" in the PASSWORD field and click on ACCEPT.
- 4) Enter the name of the module in the MODULE NAME (STC-2) field.

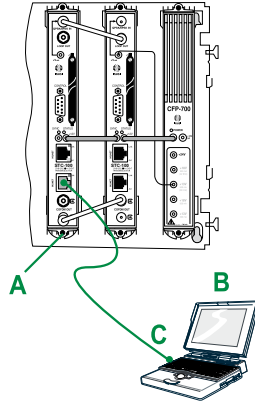

### CAUTION

The THIS STC-100 IS THE MASTER MODULE checkbox must be left unmarked for the slave modules.

- 5) Click on SAVE.
- 6) Click on EXIT in the main screen (top right corner).

## General configuration of the headend

When the master module for the headend has been defined, access to the headend is via the master module. To access the master module it is necessary to configure the IP access of the PC and enter another IP address in the web browser.

- 1) Connect the IKUNET bus for the headend with the Ethernet pigtails supplied together with each module (see example in the figure in the [General description](#) section).
- 2) In the PC, modify the IP address, following the same steps as in [Definition of the master module](#), but including the following parameters:
  - IP ADDRESS: it should follow the root of the IP address for the master module of the headend, but be out of its range. The address recommended by IKUSI for the default configuration of the master module is 192.168.1.2.
  - SUBNET MASK: 255.255.255.0
  - DEFAULT GATEWAY: 192.168.1.1
- 3) Click on the ACCEPT button.
- 4) In the web browser, enter the IP address of the master module. The default address is `http://192.168.1.5`. This takes you to the home page of the headend master module.

- 5) In the home page of the selected module, enter the word "Admin" in the PASSWORD field.
- 6) Click on ACCEPT. The main screen of the master module user interface is accessed through the HEADEND > CONFIGURATION > INSTALATION DATA window.

### Module registry and name

Proceed as follows to register the modules:

- 1) Go to the menu HEADEND > HEADEND MODULE LIST. The list of modules connected to the IKUNET bus should appear on the screen. Each row corresponds to a module. The recognition status in IKUNET and the module registry in the configuration of the headend can be distinguished by the colour of each row:
  - Blue: the module has been recognised in the IKUNET bus but has not yet been registered.
  - Red: the module is not recognised in the IKUNET bus and has been registered previously.
  - Light green: the module is recognised in the IKUNET bus and has been registered.
- 2) To register the identified modules, select the checkbox in the REGISTER column for all the modules which form part of the headend and click on REGISTER. To delete the registry of a module which is part of the headend, click on .
- 3) Name the modules (NAME column in the list of modules). Proceed as follows, module by module:
  - a) Search for the module to be named. Follow a logical order with respect to the selected assembly order. Example: follow the modules fitted from right to left: "STC-1" and "STC-2").





**NOTE**

To identify a module, in the LIST OF HEADEND MODULES table click on the cell corresponding to the MAC address of the module. The cell will change to a fluorescent green colour and the SYNC and STATUS control LEDs for the selected module flash together.

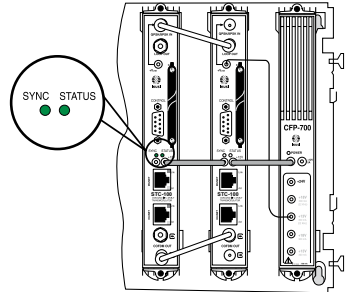

- b) Click on the magnifying glass icon of the module to be named.
- c) In the main window of the user interface go to the CONFIGURATION > CONFIGURATION menu.
- d) Enter the name of the module in the MODULE NAME field.



**CAUTION**

If the background of the field is red, this means that the data has been modified but has not yet been saved. Before changing the window or tab, the modified data must be saved (click on SAVE). Otherwise the modified data will be lost and the headend will remain in the same state as before.

## Configuration of general parameters

Permits the modification of the basic identification, network and access parameters and of the headend firmware.

To access from the main menu, click on MASTER MODULE > CONFIGURATION.

■ **INSTALLATION DATA:**

- MODEL:** shows the name of the module model.
- SERIAL NUMBER:** shows the hardware identification code.
- MAC ADDRESS:** shows the number which identifies the unit for network connection.
- MODULE NAME:** enter the module name.
- LOCATION:** allows the name of the city in which the unit is installed to be entered.
- INSTALLER:** allows the name of the person installing the equipment to be entered.
- CONTACT NUMBER:** allows the phone number of the installing company to be entered.
- DATE OF INSTALLATION:** allows the date on which the unit is installed to be entered.
- MASTER MODULE:** click on the checkbox on the right to select the module as master.
- SAVE:** click on the button to save the changes.



**IKUNET NETWORK:**

- MAC ADDRESS:** shows the number which identifies the unit for network connection.
- IP ADDRESS:** shows the number of the IP address.
- NETWORK MASK:** shows the network mask code.
- DEFAULT GATEWAY:** shows the Gateway IP address.
- DHCP POOL - START:** allows the number of the first IP address in the range of IPs to be included to be entered.
- DHCP POOL - END:** allows the number of the last IP address in the range of IPs to be included to be entered.
- MODIFY IKUNET:** click on the button to save the changes.
- RESTORE:** click on the button to omit the changes.



**PASSWORD:**

- OLD PASSWORD:** enter the current password for the home page.
- NEW PASSWORD:** enter the new password.
- CONFIRM NEW PASSWORD:** enter the new password again.
- SEND:** click on the button to save the changes.
- CANCEL:** click on the button to omit the changes.



**REBOOT MODULE:**

- REBOOT ICON (🔄):** reboots the module in the event of blocking.



**MODULE FIRMWARE UPDATE:**

- MODULE UPDATED VERSION:** shows the number of the current firmware version.
- VERSION:** list of imported firmware version numbers.
- BROWSE:** click on the button to select the route for the firmware file to be imported.
- UPDATE MODULE:** click on the button to import the selected firmware file.



**Module configuration**

Permits the modification of the operating parameters for the multiswitch, the inputs and the output of the module. To access from the main menu, click on HEADEND > HEADEND MODULES LIST.



**NOTE**

To start the headend configuration, first define the master module and the identification of the slave modules for the headend, as described in the section [Basic installation and configuration](#).

■ LIST OF HEADEND MODULES:

- MAGNIFYING GLASS ICON (🔍): click on the icon to access the module configuration.
- SUMMARY: click on the icon (📄) to display: FREQUENCY, SYMBOL RATE, BER, STATUS of the module inputs and the OUTPUT FREQUENCY.
- MODULE NAME: shows the name of each module.
- FAMILY: shows the family name of each module.
- MODEL: shows the name of the module model.
- MAC: click on the button to identify all the modules.
- MODULE IP: shows the IP of each module.
- STATUS: indicates the operational status for the module: If it is operating correctly, the icon (✅) is displayed, otherwise the icon (⚠️) is displayed.
- ALARM: this indicates whether there is an operating alarm in the module.
- REGISTER: to register the modules identified, select the checkbox in the REGISTER column for all the modules which form part of the headend and click on REGISTER: To delete the registry of a module which is part of the headend, click on (🗑️).
- REFRESH: click on the button to update the information on the screen.

**Configuration of master STC module**

**Description of the multiswitch**

This permits the modification of the multiswitch operating parameters for the master STC module. To enter from HEADEND > HEADEND MODULE LIST, click on the magnifying glass icon of the master module. Go to SETTINGS > MULTISWITCH.

- LOW LOCAL OSCILLATOR FREQUENCY (MHZ): allows to enter the local oscillator frequency value for the low band and inform the master STC module of the presence and characteristics of the multiswitch.
- HIGH LOCAL OSCILLATOR FREQUENCY (MHZ): allows to enter the local oscillator frequency value for the high band and inform the master STC module of the presence and characteristics of the multiswitch.
- NUMBER OF INPUTS. click on the dropdown menu to select the number of inputs for the master module:





- For a connection without multiswitch, select the “0” value for the master module inputs.
- For a connection with multiswitch, select the value corresponding to the number of multiswitch inputs. Next open the dropdown menu LNB / MULTISWITCH:
  - △ SATELLITE: name of the input signal to the multiswitch for identification in subsequent configurations: IKUSI recommends you identify the type of satellite, polarity and the bandwidth of the signal.
  - △ MULTISWITCH POSITION: notifies of the multiswitch input being described.
  - △ POLARITY (V): click on the dropdown menu to select the polarity: VERTICAL or HORIZONTAL.
  - △ BAND (kHz): for each polarity select HIGH once and LOW once.
- SAVE: click on the button to save the changes.

### Configuration of inputs

This permits the modification of the operating parameters for the master STC module output. To enter from HEADEND > HEADEND MODULE LIST, click on the magnifying glass icon of the master module. Go to SETTINGS > INPUT.

#### ■ INPUT:

- MULTISWITCH OUTPUT: click on the dropdown menu to select one of the following options:
  - △ For a connection with multiswitch select the input for the multiswitch to be connected to the STC.
  - △ For a connection without multiswitch select MULTISWITCH OFF.
- FI BAND: click on the dropdown menu to select the intermediate satellite band type.
- TRANSPONDER FREQUENCY (MHz): permits the frequency value to be selected for the transponder to be received.
- FREQUENCY FI (MHz): permits the required intermediate frequency value to be selected.
- INPUT REGIME (kbit/s): permits modification of the input speed value.
- INPUT SIGNAL: shows if there is an input signal.
- BER: shows the rate for the bits that were incorrectly received by the input.
- C/N (dB): shows the noise level in the input signal.
- SIGNAL POWER: shows the percentage power of the input signal with respect to the maximum possible.
- SAVE: click on the button to save the changes.

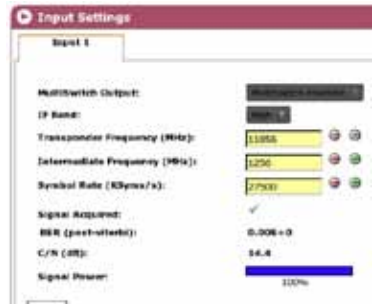

## Output configuration

This permits the modification of the operating parameters for the master STC module output. To enter from HEADEND > HEADEND MODULE LIST, click on the magnifying glass icon of the master module. Go to SETTINGS > OUTPUT.

### PARAMETERS:

- FREQUENCY (MHz):** permits the value of the output frequency to be modified.
- OFDM MODE:** click on the dropdown menu to select the OFDM transmission parameter.
- BANDWIDTH (MHz):** click on the drop down menu to select the band width value for the output signal.
- GUARD INTERVAL:** click on the dropdown menu to select the guard interval for the OFDM signal.
- CONSTELLATION:** click on the dropdown menu to select the digital constellation layout.
- CODE RATE:** click on the dropdown menu to select the FEC coding convolution code.
- ATTENUATION (dB):** click on the displacement bar to modify the output level of the signal.



### NOTE

The advanced parameters may only be modified in special cases, in the majority of installations the factory settings should not be changed.

**ADVANCED PARAMETERS:** click on the right-hand checkbox to display the **ADVANCED PARAMETERS** menu.

- I-Q FORMAT:** click on the dropdown menu to select the form (NORMAL or INVERTED) of the I-Q output channel spectrum.



### NOTE

To modify the value of the COFDM WINDOW remember that when the bandwidth of the COFDM output is reduced, the interference from the adjacent channel is reduced, but the efficiency of the guard interval is reduced proportionally and may prevent the tuning of the receivers.

- COFDM WINDOW:** click on the horizontal displacement bar to modify the band width of the COFDM channel output.
- CELL ID:** click on the horizontal displacement bar to modify the number of cells to be allocated to the COFDM channel output.

- ❑ MPE FEC DVB-H: click on the dropdown menu to activate or deactivate the error correction protocol: This permits errors in the DVB-H transmission to be detected and corrected.
- ❑ TIMESLICING DVB-H: click on the dropdown menu to activate or deactivate the timeslicing. If timeslicing is on, the receiver switches off during inactive periods and consumption for transmission in DVB-H is reduced.
- ❑ DVB-H INTERLACING: click on the dropdown menu to activate or deactivate the bit interlacing for the correction of transmission code errors in DVB-H.
- SAVE: click on the button to save the changes.
- CANCEL: click on the button to cancel the changes.
- TEMPERATURE (°C): shows the module temperature.
- MAX. BITRATE: (Mbps): shows the maximum flow of the output signal.
- PERCENTAGE OF EMPTY CARRIERS: shows the percentage of packages received without information.
- THEORETICAL MINIMUM C/N (dB): shows the theoretical signal/noise ratio required at the base of the socket so that the television receives the signal correctly.

## Configuration of slave STC module



### NOTE

The operating parameters for the slave STC module inputs and output follow the same configuration method as the inputs and output of the master STC module.

### Input configuration

Allows to change the operational parameters for the slave STC module input. To enter from HEADEND > HEADEND MODULE LIST, click on the magnifying glass icon of the slave STC module. Go to SETTINGS > INPUT.

For a description of the operating parameters of the slave STC module inputs in this manual, please go to the section [Configuration of the inputs](#).

### Output configuration

This permits the modification of the operating parameters for the slave STC module output. To enter from HEADEND > HEADEND MODULE LIST, click on the magnifying glass icon of the slave STC module. Go to SETTINGS > OUTPUT.

For a description of the operating parameters of the slave STC module output in this manual, please go to the section [Configuration of the output](#).

## Service Management

### Selection of input services

- To define the services to be emitted through the output of the DVB-T output signal, go to SERVICES > SERVICE MANAGEMENT. In the upper side of the HEADEND SERVICE MANAGEMENT window there is a table showing the services available in the input, differentiated by modules.

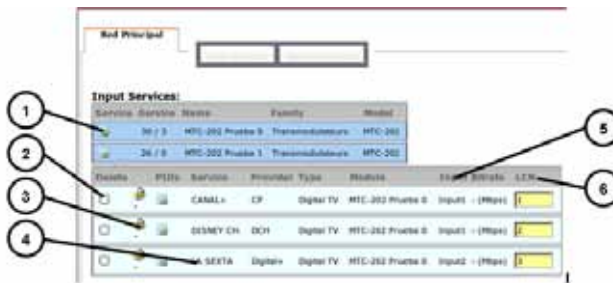

#### KEY

- Selection of STC module.
  - Selection of service to the output signal (if the checkbox is not displayed, the service has already been selected at the output).
  - Service type.  
Lock closed = encrypted.  
Lock open = free.
  - Service: name of service (contextual menu when passed with the cursor: information on Service ID).
  - Input: module input number (contextual menu when passed with the cursor: information on Original Network ID and Transport Stream ID).
  - Original LCN. Logic Control Number emitted by the operator.
- Click on the icon on the left of the row of each module (position 1 in the above figure) to go to the list of input services.
    - To select a particular service, activate the checkbox in the ADD column (2).
    - When all the services of a module have been enabled for the output signal, click on the SAVE SERVICES button.

## Management of output services

**Output Services:**

Delete	PIDs	Service	Provider	Type	Module	Input Bitrate	LCN
<input type="checkbox"/>		CANAL+	CP	Digital TV	MTC-202 Prueba 0	Input1 - (Mbps)	1
<input type="checkbox"/>		DISNEY CH.	DCH	Digital TV	MTC-202 Prueba 0	Input1 - (Mbps)	2
<input type="checkbox"/>		LA SEXTA	Digital+	Digital TV	MTC-202 Prueba 0	Input2 - (Mbps)	3

**Output Bitrate:**

Name	Family	Model	Max. Bitrate	Min. Nulls	Curr. Nulls	Max. Nulls
MTC-202 Prueba 0	Transmodulateurs	MTC-202	-(Mbps)	- %	- %	- %
MTC-202 Prueba 1	Transmodulateurs	MTC-202	-(Mbps)	- %	- %	- %

### KEY

- ① Deletion of the output service.
- ② Lock open: service processing not encrypted.
- ③ Lock closed: service encrypted.  
“Ok” icon = unencryption correct.  
“Not ok” icon = unencryption failed.
- ④ LCN. Logic Control Number emitted by the DVB-T output signal of the headend.  
Yellow cell = LCN free.
- ⑤ Monitoring of bandwidth of available output signal.



### NOTE

If the bandwidth is saturated, delete the output services not required selecting the checkboxes in the DELETE column (①) and clicking on SAVE SERVICES.

- LCN management (④):
  - The DVB-T input services have an LCN (Logic Control Number) which is transmitted in the output services (see LCN column).
  - The DVB-S/S2 input services do not usually have an LCN. The headend automatically allocates an LCN for the DVB-T output signal of these services.
  - To modify an LCN (see LCN column, cells with yellow background):
    - i) Place the cursor in the LCN cell to be modified.
    - i) Modify the LCN.
    - i) Click on the SAVE LCN VALUES button.
- Output services saturation level:
 

The saturation level of the output multiplexes can be controlled with the instruction on empty packets (stuffing) and the information about the data transfer speed (⑤).

  - The information on empty packets reflects the available bandwidth in the output multiplex and is indicated in real time in the lower table OUTPUT BITRATE of the HEADEND SERVICE MANAGEMENT window with the following columns:
    - △ MAX. BITRATE: data transfer speed of the output multiplex.

- △ MIN. NULL: minimum percentage of empty packets performed.
- △ ACT. NULL: percentage of actual empty packets.
- △ MAX. NULL: maximum percentage of empty packets performed.
- The BITRATE column in the above tables INPUT SERVICES and OUTPUT SERVICES provides information on the individual data transfer speed for each service.

## Advanced functions

This section describes the additional functions of the user interface.



### NOTE

The word “Live” appears in a red rectangle in the upper right corner of the main screen. This means that the headend is checking evaluation data.



### NOTE

In local configuration there are contents which are also displayed in HEADEND > HEADEND MODULE LIST > DETAILS

## Save/Restore Function

This allows the current configuration of the selected model to be stored in a text file (“txt” extension) and then imported later. To access from the main menu, click on HEADEND > HEADEND MODULE LIST > ACCESS MODULE > GENERAL > SAVE/RESTORE.

- **Save Function.** Select the tab for the module for which you wish to save the configuration, select **SAVE THE CONFIGURATION** and click on **REBOOT**.
- **Restore Function.** Select the tab for the module from which you wish to import the configuration, select **RESTORE THE CONFIGURATION** and click on **reboot**. This function can be used to streamline the configuration process for future stations.

## Internet Access

The Internet access not only allows the headend to access the Internet (for example to display its location), but it allows an operator to access and configure the headend from the exterior. To access from the main menu, click on HEADEND > ACCESS VIA INTERNET.

**CONFIGURE ACCESS VIA INTERNET:** select the checkbox to activate this function and then configure the headend access to Internet (IP address, network mask, and default gateway).

- **MAC ADDRESS:** headend identifier for the network connection.
- **USE DHCP TO ASSIGN IP ADDRESS:** activate the checkbox so that the DHCP server automatically assigns an IP address: Deactivate the checkbox to enter the IP address, network mask and default gateway manually.
- **IP ADDRESS:** enter the IP address if the DHCP is not enabled.
- **NETWORK MASK:** enter the network mask if the DHCP is not enabled.
- **DEFAULT GATEWAY:** enter the default gateway if the DHCP is not enabled.

- PRIMARY DNS SERVER: to use a DNS server, enter the IP address of the primary DNS server provided by the domain supplier.
- SECONDARY DNS SERVER: to use a secondary DNS server, enter the IP address of the secondary DNS server provided by the domain supplier.
- MODIFY WITH: NETWORK: click on the button to save the changes.
- RESTORE: click on the button to omit the changes.

## Network functions

This enables the parameters relating to the distribution network to be consulted and configured. To access from the main menu, click on HEADEND > OUTPUT NETWORK.

- In the NETWORK CONFIGURATION tab the name and network identifier can be consulted and edited.
  - EDIT/SAVE: click on the icon (✎) to modify the network name and the NID. Next, the Save icon is displayed (💾). Click on Save to store the network name and the NID.
  - NETWORK NAME: name of the distribution network.
  - NID: network identifier, required to tune the supplier service channels.
  - NO. CURRENT/REGISTERED MODELS: quantity of headend modules and quantity of registered modules.

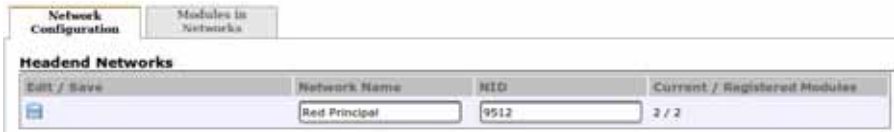

- The MODULES IN NETWORKS tab contains all the information regarding the network:
  - NAME: module name.
  - INPUT FREQ. (Hz): shows the input frequency.
  - OUTPUT FREQ. (Hz): shows the output frequency.
  - FAMILY: name of module family.
  - MODEL: name of module model.

The screenshot shows the 'Modules in Networks' tab. Below the tab is a table titled 'Modulos de la Red: Red Principal'. The table has columns for 'Name', 'Network', 'Input Freq. 1', 'Input Freq. 2', 'Output Freq.', 'Family', and 'Model'. The first row shows a module named 'MTC-202 Prueba 0' with an input frequency of 1288 Hz, an output frequency of 482000 Hz, and a model of 'MTC-202'.

Name	Network	Input Freq. 1	Input Freq. 2	Output Freq.	Family	Model
MTC-202 Prueba 0	Red Principal	1288	1229	482000	Transmodulateurs	MTC-202



## Advanced global transport processing

Enables the configuration of all the additional functions of the modules, the network and the services. To access from the main menu, click on SERVICES > SERVICE MANAGEMENT.

In the MAIN NETWORK tab the advanced operating of the network can be edited, and services not included in the input can be selected or blocked.

### □ NIT REGENERATION SETTINGS:

- △ AUTO SERVICES LIST: Select the checkbox to include a service\_list\_descriptor in the NIT, generated by the master module and based on the services available in the headend output.
- △ NIT MODEL: Click on the dropdown menu to select one of the three available NIT models:
  - WITHOUT NIT MODEL: the master module generates an NIT from scratch, from the selected output frequencies, the output services and the selected LCN.
  - NIT INTEGRATION: calculates a new NIT from the NIT in the input signals, if there is relevant information in the input NIT this is sent to the output.
  - INPUT NITS: calculates a new NIT from the NITs selected as model for the DVB-S/S2 input signals.
  - FILE NITS: the NIT are generated based on user-loaded information from an external file.



### NOTE

The headend automatically allocates an available LCN value for the satellite services.

- △ OFFSET LCN: permits the addition of an offset LCN.
- △ LCN MODE: click on the dropdown menu to select the LCN transmission standard in the NIT: OFF (no LCN entered), EUROPEAN STANDARD (default), NORDIG V1 2 STANDARD, NORDIG V2 3 STANDARD, GENERIC MODE (for example for Australia).
- △ DOWNLOAD TABLES: click on the word NIT-SDT to download the tables to the PC.
- ADD SERVICES NOT PRESENT IN THE INPUTS:
  - △ MODULE - INPUT: click on the dropdown menu to select the module and the input from which you wish to select services not included.
  - △ SID: permits the addition of a not included service identification number which you wish to select.
  - △ ADD: click on the icon () to save the changes.

- ❑ **ADVANCED MODULE CONFIGURATION:** click on SEE MODULES to open the dropdown menu. This function permits the management of the non-referenced PID for each module which are not listed in any table, and may be unblocked.



**NOTE**

In an STC module, by default no output service is selected and the required output services must be selected one by one. In an STC module, all the output services are selected by default and you have to select the output services you wish to delete one by one.

- From the EXTERNAL NIT tab a file of NIT tables can be imported. Click on SELECT FILE TO BE LOADED to activate the import function.
  - a) Click on BROWSE and select the path where the NIT table file is located.
  - b) Click on SEND to import the file or click on CANCEL to deactivate the import function.

**Reports**

These contain all the updated information about the operating of the headend. There are 5 different reports according to the content: STATUS INFORMATION, GENERAL REPORT, GENERAL HEADEND REPORT, SERVICES REPORT, HEADEND LOGS.

**Status information**

Located in the menu MASTER MODULE > STATUS INFORMATION. Contains all the information regarding the status of the module communication:

- **GENERAL:**
  - ❑ **INPUT:** input communication status.
  - ❑ **OUTPUT:** communication status of output.
  - ❑ **GENERAL:** general operating status of headend.

**DETAILS:** this is an information file for the headend status which includes the following states: GENERAL, INPUT, DISEQC, TS PROCESSING, CAM, OUTPUT.



**NOTE**

To download information from this tab, click on the SAVE TO PC button in the lower part of the screen.



## General report

Located in the menu MASTER MODULE > GENERAL REPORT. Contains all the information regarding the general parameters of the headend:

- **IDENTIFICATION:** general identification parameters for the headend.
- **NETWORK:** network parameter information.
- **SETTINGS:** operational parameters for input, output, LNB / Multiswitch, LNB.



## General headend report

Located in the menu REPORTS > GENERAL HEADEND REPORT. Contains information regarding:

- **INSTALLATION DATA:** general identification parameters for the headend.
- **SYSTEM TIME AND COUNTRY:** time configuration parameters for the headend.
- **OUTPUT NETWORKS:** network operating parameters.



## Service report

Located in the menu REPORTS > SERVICE REPORT. Contains all the information about the services:

- **INPUT SERVICES:** click on the icon (📄) for more detailed information.
- **OUTPUT SERVICES:** click on the icon (📄) for more detailed information.
- **OUTPUT BITRATE:** click on the icon (📄) for more detailed information.



## Headend logs

Located in the menu REPORTS > HEADEND LOGS. Contains all the information about the system logs.

- **SHOW INPUTS:** click on the dropdown menu to select the filter by level option.



## Advanced functions/Reports

- **SHOW INPUTS:** click on the second dropdown menu to select the filter by process state option.
- **APPLY FILTERS:** click on the button to start the filter process.

# Unit recycling



## RECYCLING OF ELECTRICAL AND ELECTRONIC EQUIPMENT

**(Applicable in the European Union and in European countries with selective waste collection systems.)**



This symbol on your unit or its packaging indicates that this product cannot be treated as general domestic waste and must be handed in at the corresponding point of collection for electric and electronic equipment. By ensuring this product is disposed of correctly you will help prevent negative consequences for the environment and human health, which could otherwise be caused by inappropriate waste handling of this product. Recycling of materials helps preserve natural resources. For more detailed information on the recycling of this product, please contact your local council, your nearest collection point or the distributor from whom you purchased the product.

# CE Certificate

By reproducing the CE marking, IKUSI guarantees unit compliance with the corresponding harmonised standards.

## EC-Declaration of Conformity

**CE** marking

We, Manufacturer

IKUSI, **Angel Iglesias, S.A.**  
Paseo Miramón, 170  
E-20009 San Sebastián, Spain

declare that the product

**STC-100 ,, STC-200 ,, STF-100**  
**DVB-S/S2 to DVB-T Transmodulators**

is in conformity with

**Council Directive 89/336/EEC (EMC Directive)**

Standards to which conformity is declared:

**EN 50083-2 :2007**

Cabled distribution systems for television and sound signals.  
Part 2: Electromagnetic compatibility for equipment.



**Angel Iglesias, S.A.**

San Sebastián, May 2010

Luis Rodríguez Navarrete

— R&D Director —





Ángel Iglesias, S.A.  
Paseo Miramón, 170  
20009 San Sebastián, Spain  
Tel. +34 943 44 88 00  
Fax +34 943 44 88 20  
ikus@ikus.com  
www.ikus.com

120127A

